

Subminiature Sealed Snap Action Switch

DC Series

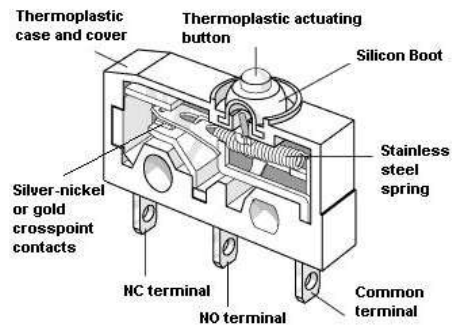

Features

- Enclosed switch complying with IP 6K7
- Silicon-free version available
- Models available for operating temperatures up to 120°C
- Rated for currents up to 10.1 amps at 250VAC
- Range of auxiliary actuators available (can also be retrofitted)
- Various contact materials available, depending on application
- Mechanical life: min. 1×10^6 operations
- Wide variety of terminal options

Electrical Ratings and Operating Life

Switch Series	According to EN61058-1		According to UL1054	
	Nominal Load	Operation cycles	Nominal Load	Operation cycles
DC1	6A, 250V~	10,000	5A 125/250 VAC, 1A 48VDC	6,000
DC2	10(1.5)A, 250 V~	10,000	10.1A 125/250 VAC 1/4HP 125VAC	6,000
DC3	0.1A 250 V~	50,000	0.1A 125/250 VAC	100,000

Technical Specifications		Material Specifications	
Temperature Rating:	-40° to +85°C / +120°C (without wire leads) -40° to +85°C / +105°C (with wire leads)	Case:	PET / PBT
Degree of Protection:	IP67	Actuator button:	PBT (UL 94 V-0) 120°C POM (UL 94 HB) 85°C
RoHS Compliant:	Yes	Contacts:	AuAgPt (Crosspoint), AgNi,
UL File Number:	E314201	Terminals:	CuZn (silver plated)
		Auxiliary actuator:	Stainless steel or plastic



Specifications subject to change



Subminiature Sealed Snap Action Switch

DC Series

Dimensions - millimeter

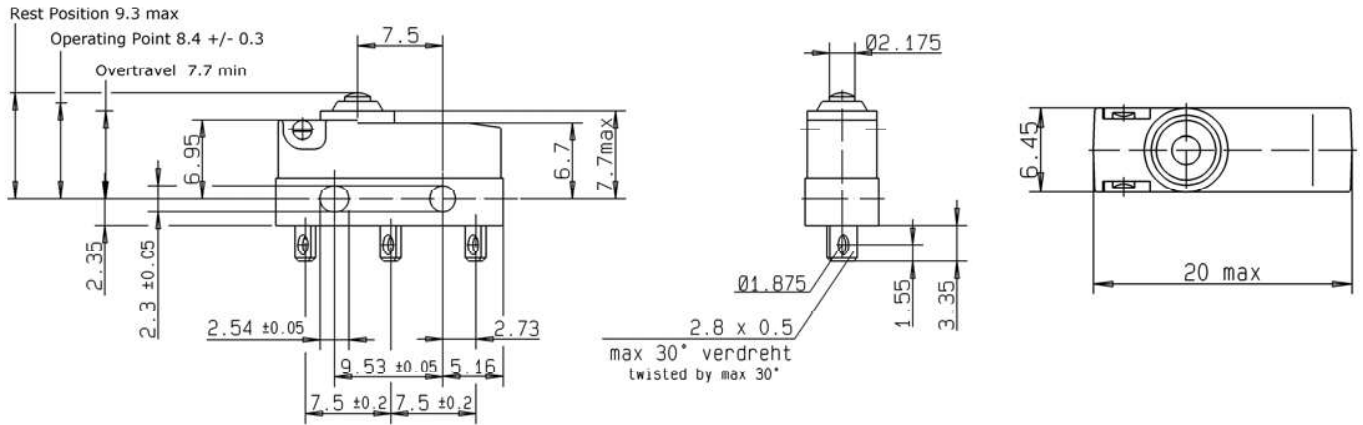

Models with Wire Leads

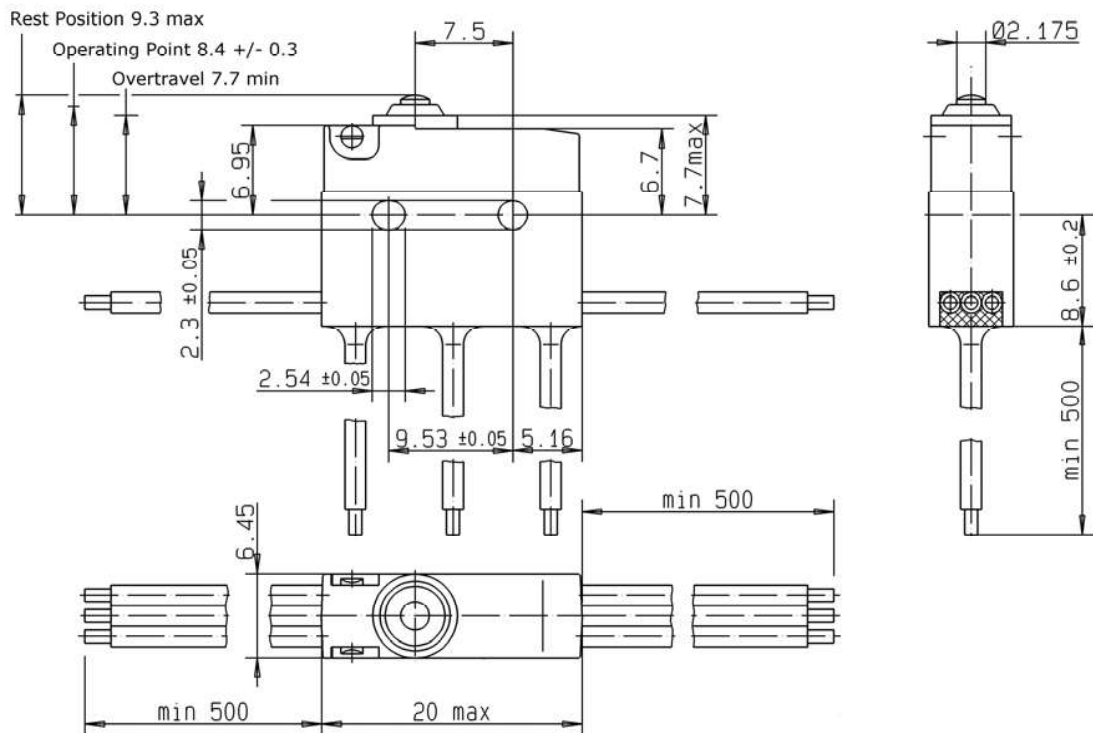

Wire Colors: Common: Black

Normally Open: Blue

Normally Closed: Grey

Subminiature Sealed Snap Action Switch

DC Series

Terminal Options inches (mm)

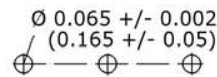
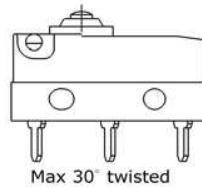
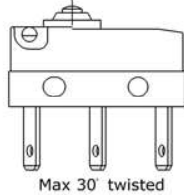
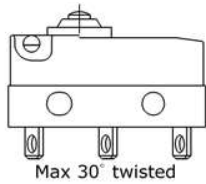

Hole pattern for .051" (1.3) pcb

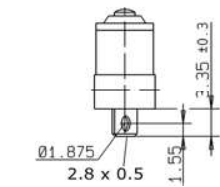
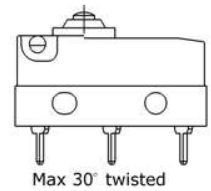

Short Solder Code A

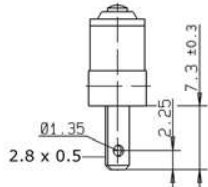

0.110 x 0.020 QC Code L
(2.8 x 0.5)

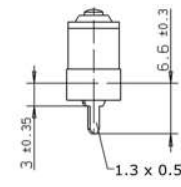

0.051 X 0.020 PCB Code H
(1.3 x 0.5)

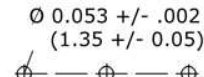

Hole pattern for .024" (0.6) pcb

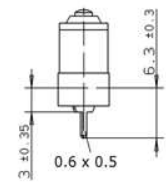

0.024 x 0.020 PCB Code K
(0.6 x 0.5)

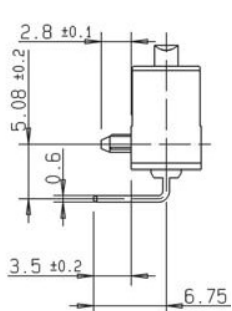

Left side pcb with location pins

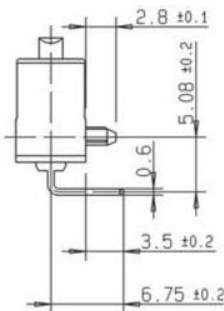

Right side pcb with location pins

L
T
T
M
L

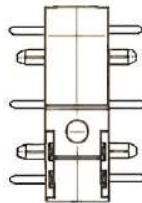

R
I
G
H
T

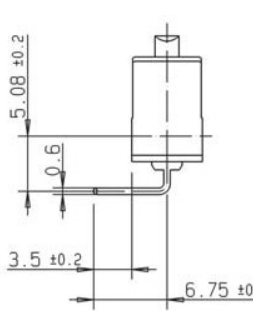

Left side pcb terminals

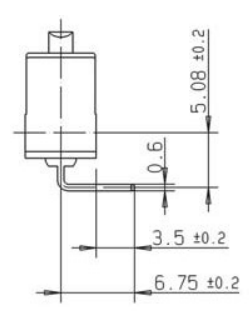

Right side pcb terminals

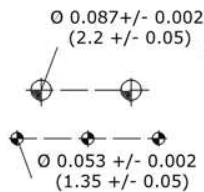

Hole pattern for pcb terminals with location pins

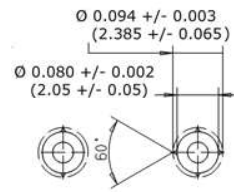

(Post Dimensions)

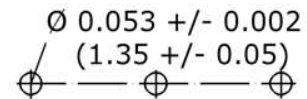

Hole pattern for pcb terminals without location pins

Subminiature Sealed Snap Action Switch

DC Series

Ordering Information

DC Series	3	C
		Code
		+85C Operating Temperature
		E SPST NO
		F SPST NC
		G SPDT
		+120C Operating Temperature
		A SPST NO
		B SPST NC
		C SPDT

Code	EN 61058 Rating	UL1054 Rating
1	6A 250VAC	5A 125/250VAC, 1A 48VDC
2	10(1.5)A 250VAC	10.1A 125/250VAC, 1/4HP 125VAC
3	0.1A 250VAC	0.1A 125/250VAC 0.1A 30VDC

A	Terminal Type	Notes
A	Short Solder	1
B	0.02" (0.5) Leads (No UL)	4, 8
C	0.03" (0.75) Leads (No UL)	4
H	0.05 x 0.02 (1.2 x 0.5) PCB	1
K	0.02 x 0.02 (0.5 x 0.5) PCB	1, 6
L	0.11 x 0.02 (2.8 x 0.5) QC	1
N	Without Leads (Type B)	5
P	Without Leads (Type A)	5
Q	Without Leads (No Cut Out)	8
Non-European Versions		
D	Leads 18 awg (UL approved)	4, 7, 9
E	Leads 16 awg (UL approved)	4
M	Leads 20 awg (UL approved)	3, 4

1	AA	Code	Actuator Type
		AA	Spherical Head button
		LB	Short straight lever 0.169 (4.8)
		RB	Short roller lever 0.098 (2.5)
		RC	Roller lever 0.185 (4.7)

* For additional actuator options contact factory

** Do not use plastic levers with 120°C rated switches

Notes:

Wire leads 500 mm min. (approximately 20" long)

1. Only available with terminal configuration 1
2. +85C rated only
3. Only available with DC1 and DC3
4. Wire versions only rated to +105C
5. Only available with terminal configuration 3 or 4

6. Only available with terminal configuration 1, 6, 7, 8, 9
7. Only available with terminal configuration 5
8. Only available with DC3
9. Not available with DC2

1	30° Twisted
3	Leads on Actuator Side
4	Leads on Opposite Side from Actuator
5	Leads Attached to Underside
6	PCB Terminals Right Hand Side
7	PCB Terminals Left Hand Side
8	PCB Terminals Right Hand Side with Location Pins
9	PCB Terminals Left Hand Side with Location Pins

Contact

Call, fax or visit our Website for more information.

ZF Electronics Corporation
11200 88th Avenue
Pleasant Prairie, WI 53158

Phone: 262.942.6500
Web: www.cherrycorp.com
Email: cep_sales@zf.com
Fax: 262.942.6566

The manufacturer accepts no liability for errors or non-availability, and reserves the right to change specifications without prior notice.

Technical data relates to product specifications only. Features may differ from those described. Only drawings combined with product specifications shall be deemed binding.

© 2007 ZF Electronics Corporation

Last Updated: 071211

